

NOTES:

1. INPUT VOLTAGE: 28 VOLTS DC
 - CLOCK: 5mA MAX
 - 429 BUS: 300mA MAX
2. LIGHTING VOLTAGE: 28V, 150mA MAX
3. LIGHTING COLOR: BLUE WHITE
4. WEIGHT: .5 LB MAX
5. MATERIAL:
 - CASE: ALUMINUM ARINC 408A ATI2
 - BEZEL: FINISH IS LUSTERLESS BLACK IAW
 - FED-STD-595 NO. 37078
6. TIME IS MAINTAINED BY AN INTERNAL BATTERY WHEN EXTERNAL POWER IS REMOVED. ANTICIPATED BATTERY LIFE IS 10 YEARS.

REV	REVISIONS		DATE	APPROVED
	DESCRIPTION			
-	INITIAL RELEASE #97777		1/17/02	

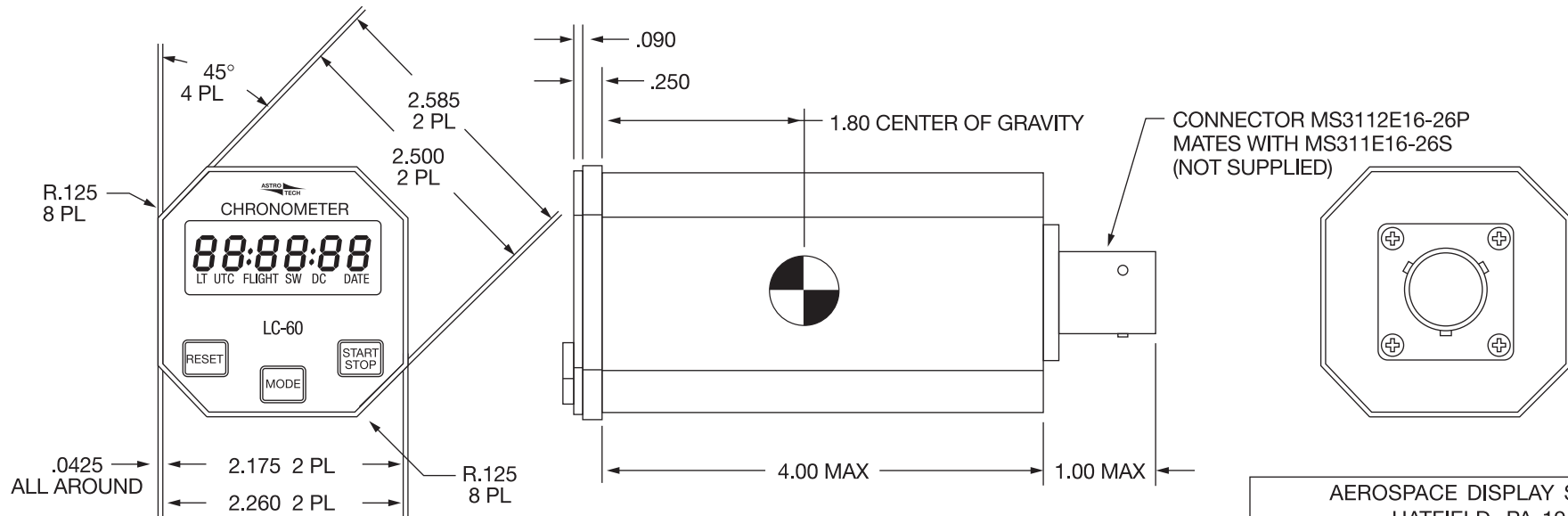

AEROSPACE DISPLAY SYSTEMS HATFIELD, PA 19440				
SIZE B	CAGE CODE 65907	DWG NO AT6451R3	REV —	
SCALE	1/1	AT6421R3S02	SHEET	2 OF 3

65907
DWG NO
AT6451R3
SHT 2
REV —

REVISIONS				
ZONE	REV	DESCRIPTION	DATE	APPROVED
	-	INITIAL RELEASE #97777	1/17/02	

INSTALLATION WIRING DIAGRAM

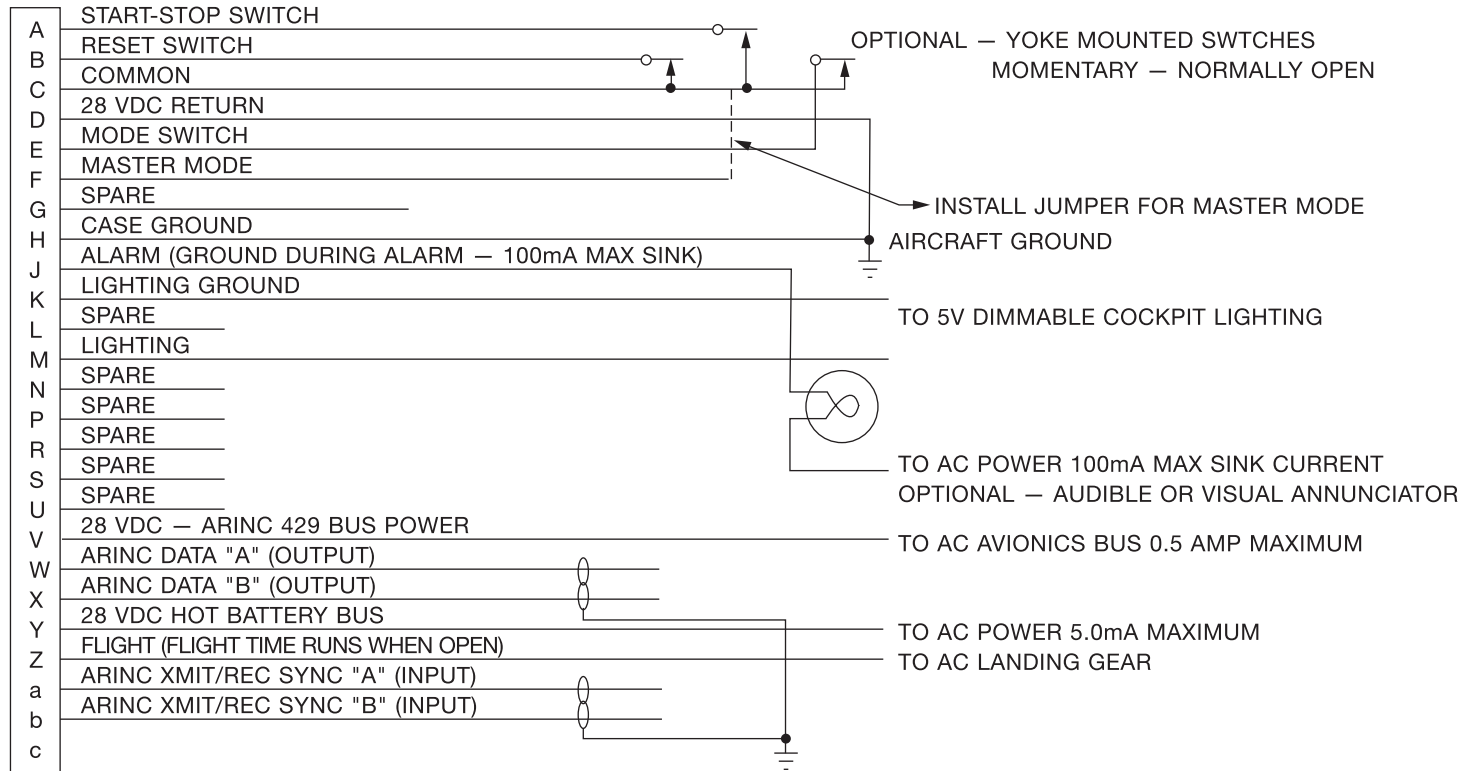

CONNECTOR - MS3112E-16-26P
 AC MATING CONNECTOR - MS3116E16-26S

65907
 DWG NO
 AT6451R3
 SH-3
 REV -

AEROSPACE DISPLAY SYSTEMS HATFIELD, PA 19440				
SIZE B	CAGE CODE 65907	DWG NO AT6451R3	REV -	
SCALE NONE	AT6451R1S03	SHEET	3 OF 3	