

LC-90 CHRONOMETER

LC-90 DESIGN BASIS

The Aerospace Display Systems LC-90 is an ARINC 3ATI size chronometer designed for air transport service.

The ADS model LC-90 chronometer is designed for air transport use. It incorporates ARINC 429 communications for interconnections to other systems in the aircraft. The layout and design of the LC-90 make it an economical and reliable choice for OEM and retrofit installations with ease of maintenance. The solid state modular construction is resistant to dirt, vibration and the wear of mechanical clocks. A single user-friendly "push to set" knob easily sets the desired time or date.



LC-90 SPECIFICATIONS

Clock

24 hour Universal Coordinated Time (UTC).

Date

Date is displayed as DD/MM/YY and is year 2000 compliant.

Elapse Time

Range is 00 to 59 minutes, 00 to 99 hours. Elapsed Time can be started - stop - restarted or reset.

Display

Solid state Liquid Crystal Display (LCD) technology provides a continuous readout using negative image (white characters on black background) for excellent visibility during all operating conditions.

Lighting

The system provides high brightness back-lighting during day operation and normal dimming control for night operation. Dimming is accomplished from the aircraft's 5VAC, 400Hz lighting bus.

Weight

Less than 30 ounces (850 grams).

Chronograph

Range is 00 to 99 minutes, 00 to 59 seconds. Seconds are indicated by the sweep second pointer. An optional external chronograph switch can be used. seconds. Seconds are indicated by the sweep second pointer. An optional external chronograph switch can be used.

Installation

Installs into a standard 3ATI (3-inch air transport indicator) panel cutout using an ARINC 408A standard mounting clamp.

Environmental

The LC-90 clock meets all of the applicable sections of RTCA DO-160.

Power

Power is supplied to the clock by the aircraft's +28 VDC Main bus and the +28 VDC Hot Battery bus. The +28 VDC Main bus draws a maximum current of 100mA and the +28 VDC Hot Battery bus draws 35mA of current.



TRANSICOIL
AEROSPACE SOLUTIONS

Since 1969 AvtechTye has been a leader in the design, development, and manufacture of electronic systems for the aerospace industry, with a focus in three product groups: Audio, Avionics and Structures.

AvtechTye products are flying onboard 42 aircraft types within the air transport, regional commuter, and business jet sectors, serving 450 customers in 49 countries of the world.

Our versatility in supporting aerospace electronics requirements ranges from the custom design and manufacturing of complex power supplies to complete Digital Audio Systems.

AvtechTye is certified to ISO9001, AS9100 and the FAA's ACSEP. Product Support includes in-house repair services (FAA approved Repair Station #IG6R621N), loaner/exchange programs, and both in-house and offsite airline training.

Transicoil LLC
9 Iron Bridge Drive
Collegeville, PA 19426

www.Avtechttyee.com

Tel: (484) 902-1100
Toll Free: (800) 323-7115
Fax: (484) 902-1150

© AvtechTye Corporation, 2020

PART NO.	MODEL	DESCRIPTION
AT945012	LC-90	Panel mounted, aircraft powered, 5VAC or DC lighting

STC Part Number: DNM-100-200-02

FEATURES

- Liquid Crystal Display with dual numeric readout
- Sweep second hand
- ARINC 3ATI case
- ARINC 429 bus sends date & time
- Date in DDMMYY format
- Elapsed time
- Chronograph
- Universal Coordinated Time (UTC)

INSTALLATION DIAGRAM

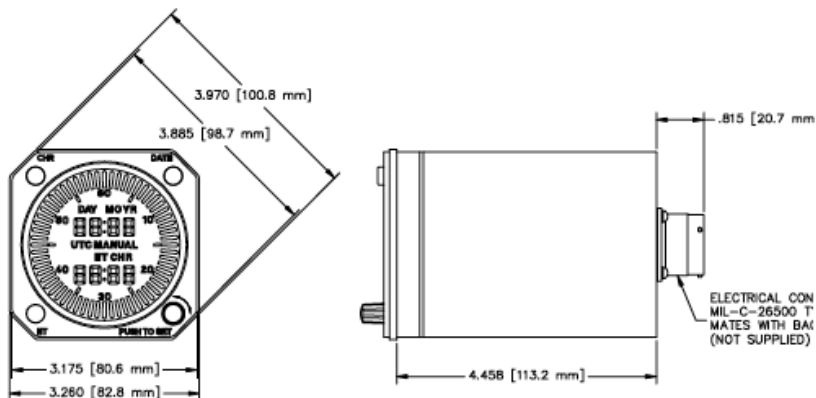

Transicoil LLC
 9 Iron Bridge Drive
 Collegeville, PA 19426

www.Avtechtylee.com

Tel: (484) 902-1100
 Toll Free: (800) 323-7115
 Fax: (484) 902-1150